

DAKOTA™ 2006 DUMP BOX ILLUSTRATED PARTS MANUAL



INTRODUCTION

To ensure optimum performance and safety, always purchase genuine **DAKOTA** replacement parts and accessories. NEVER USE “WILL-FIT” REPLACEMENT PARTS AND ACCESSORIES MADE BY OTHER MANUFACTURERS. Using either inappropriate or unapproved replacement parts and accessories may result in progressive damage to the product and voids the warranty.

This manual provides a listing to the parts and assemblies that are available as replacement parts. For the most part, common hardware is not listed in this manual. Be sure, however, that when replacement of hardware is necessary, to replace with the same length, diameter, and grade.

The illustrations used in this Parts manual are for reference to replacement parts only. This manual is not to be used for assembly. If in need of replacement parts or in need of a replacement part not called out in this manual, contact an authorized Dakota dealer. To locate a local dealer, go to www.dakotapeat.com.

TABLE OF CONTENTS

Introduction	2
525 Dump Box	3
525 Dump Box	4
525 Dump Box	5
525 Dump Box	6
550 Dump Box	7
550 Dump Box	8
550 Dump Box	9
Warranty	10
Notes	11

525 DUMP BOX

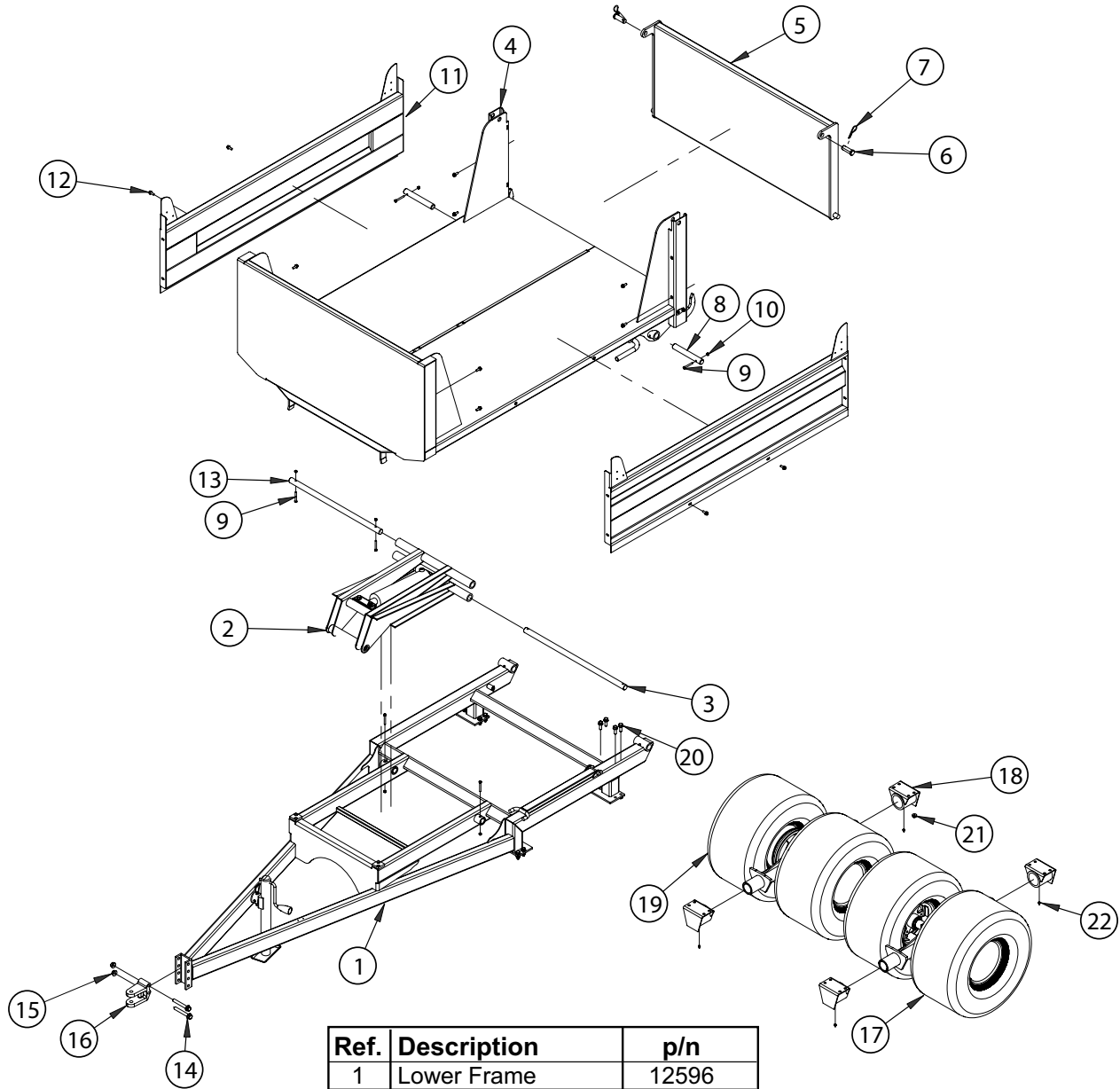

Ref.	Description	p/n
1	Lower Frame	12596
2	Hoist	12595
3	Pin	12652
4	Box	12649
5	Tailgate	12635
6	Pin, Clevis	2FR16240
7	Hitch Pin	12455
8	Pin	12451
9	Screw, Cap	1C0540
10	Nut	61D05
11	Side Wall	12628
12	Screw, Flange Head	35C0616
13	Pin	12653
14	Screw, Flange Head	35C1072
15	Nut, Flange	89D10
16	Hitch	10004
17	Axle Assembly - LH	12663
18	Pivot	11415
19	Axle Assembly - RH	12611
20	Screw, Flange Head	35C0824
21	Nut, Flange Head	89D08
22	Grease Fitting	13548

525 DUMP BOX

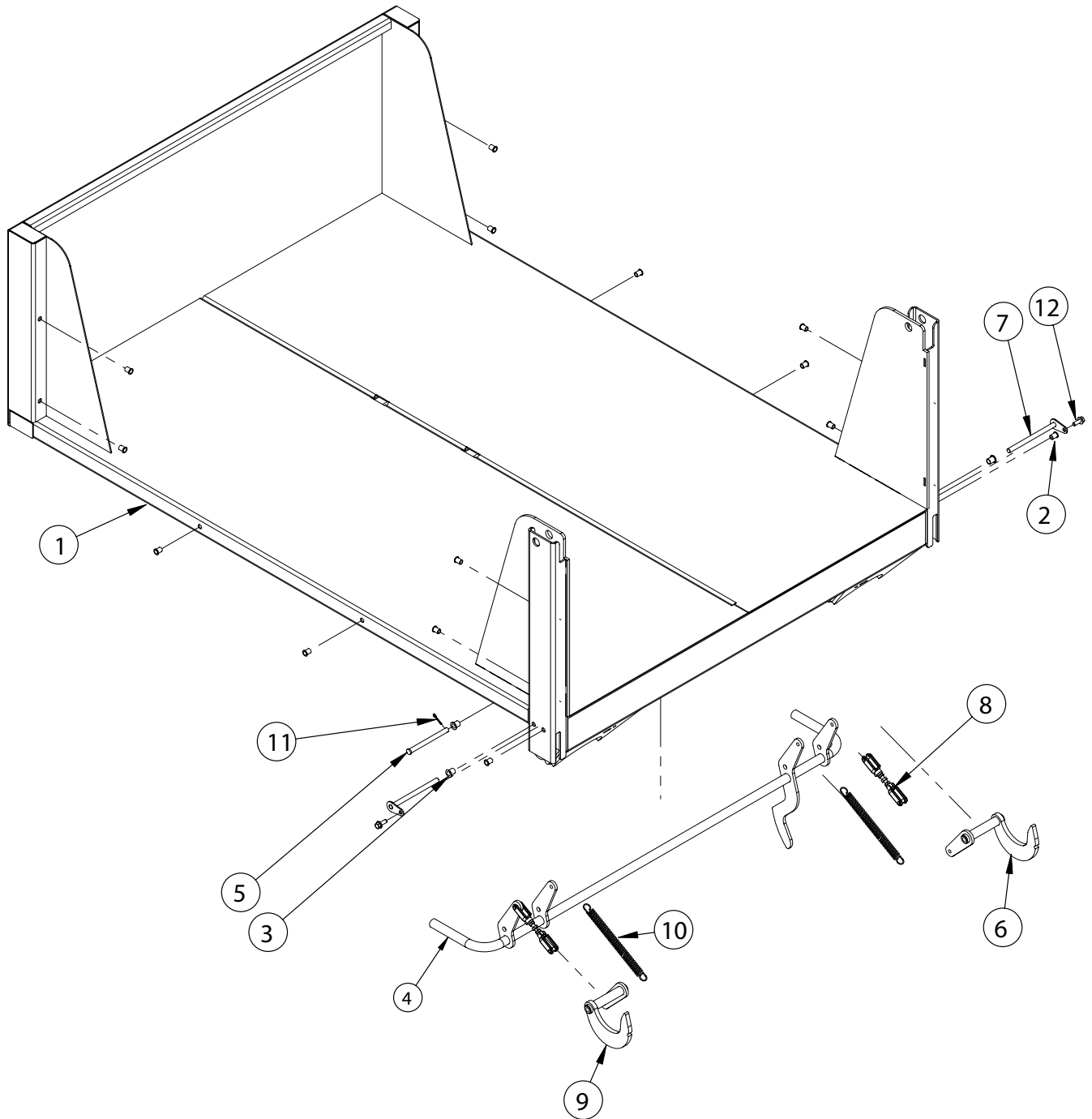

Ref.	Description	p/n
1	Dump Box	12613
2	Rivnut	11569
3	Bushing	12457
4	Manual Release	12645
5	Pin, Pivot	12465
6	Right Hook	12647
7	Pin, Latch	12651
8	Connecting Link	12476
9	Left Hook	12648
10	Spring, Latch	12399
11	Cotter Pin	1F416
12	Screw, Flange Head	35C0616

525 DUMP BOX

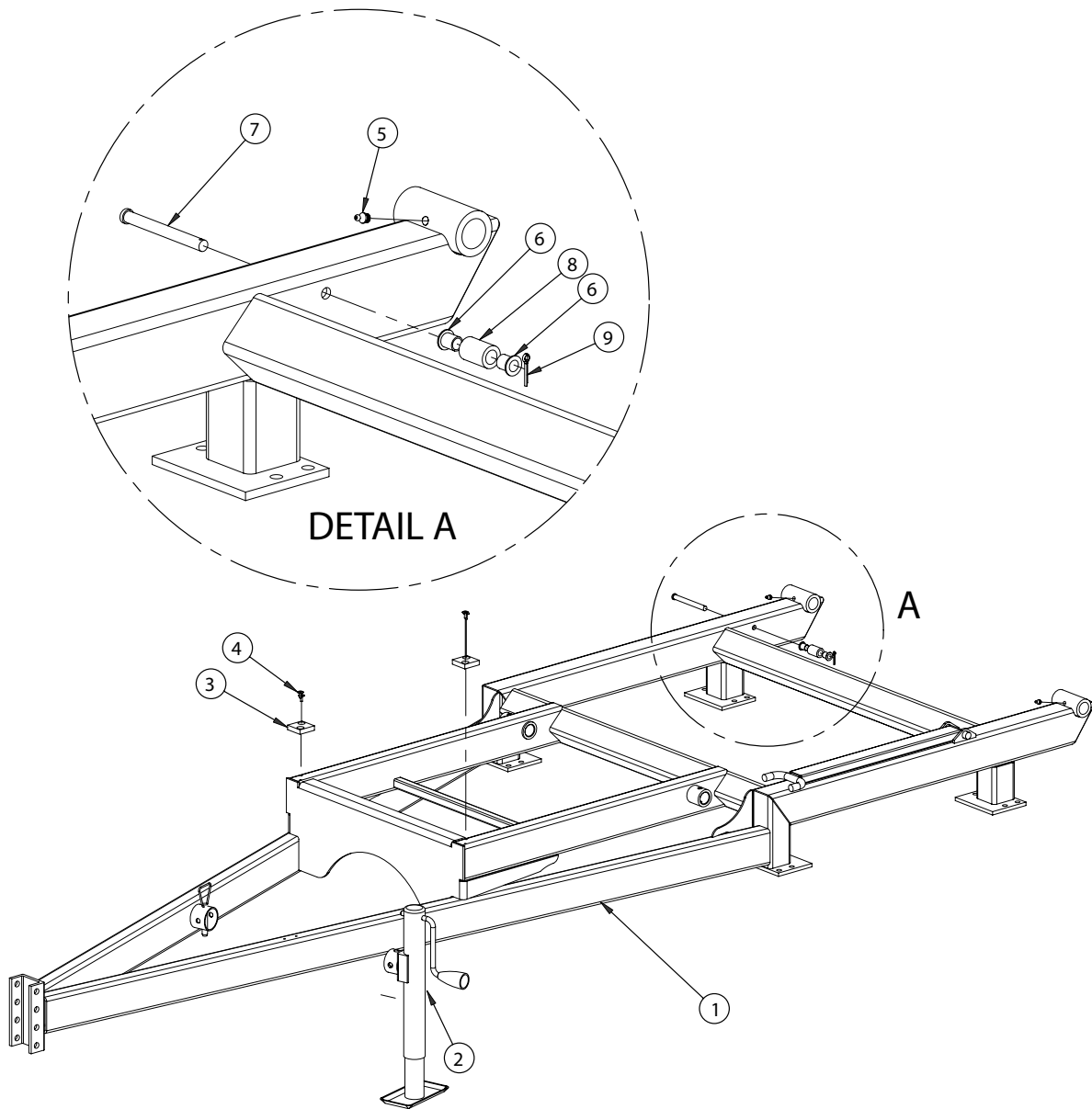

Ref.	Description	p/n
1	Lower Frame	12597
2	Jack	10003
3	Pad	12456
4	Rivet, Pop	11683
5	Grease Fitting	13548
6	Bushing	12457
7	Pin, Pivot	14507
8	Tube	12392
9	Cotter Pin	1F416

525 DUMP BOX

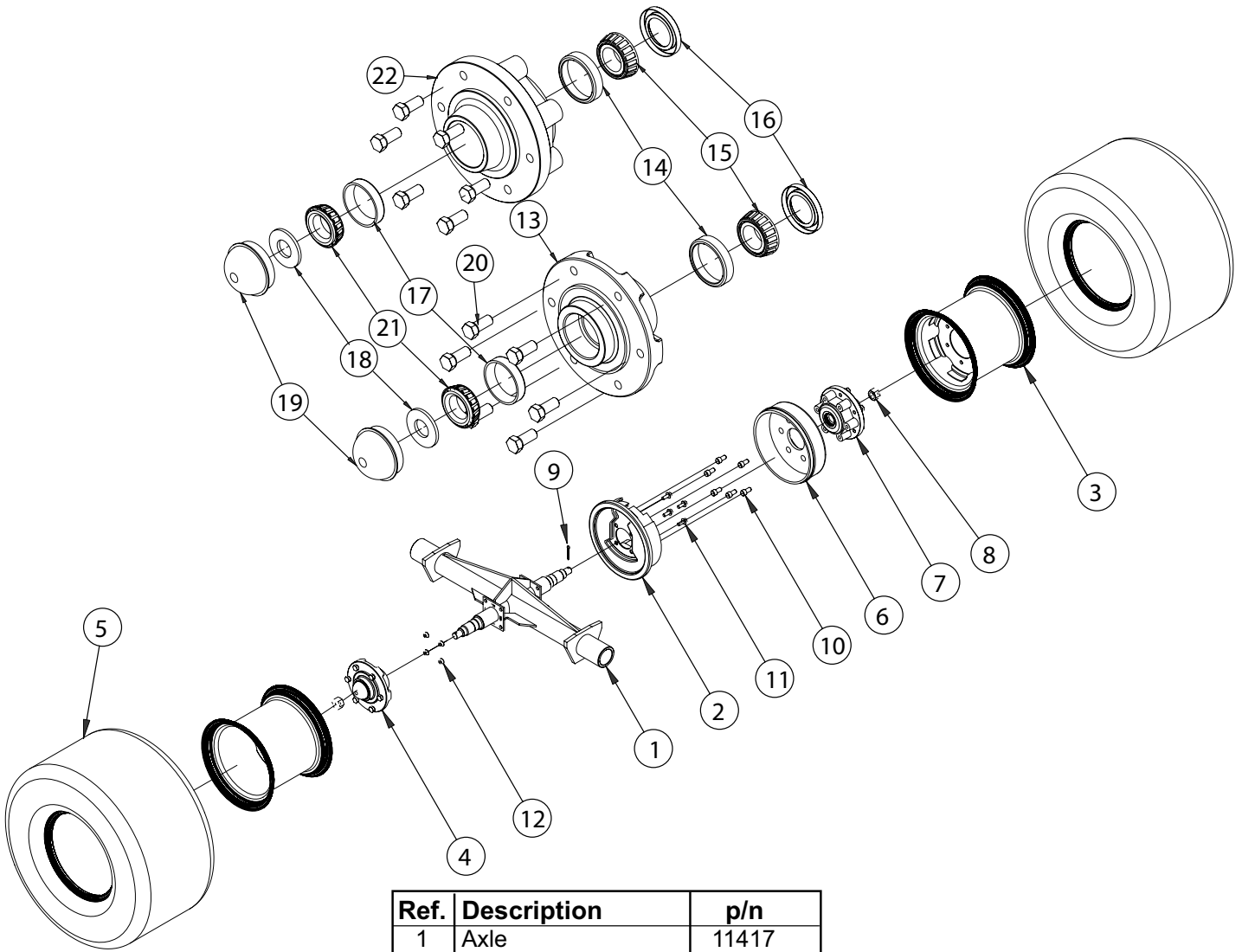

Ref.	Description	p/n
1	Axle	11417
2	Brake Assembly - RH Brake Assembly - LH	11420 11419
3	Wheel	10051
4	Idler Hub Assembly	10050
5	Tire	10052
6	Brake Drum	11416
7	Brake Hub Assembly	12335
8	Castle Nut	41D14
9	Cotter Pin	1F528
10	Screw, Socket Head	74G0816
11	Screw, Flange Head	35C0616
12	Nut	89D06
13	Idler Hub	12659
14	Cup, Inner	10203
15	Bearing	10205
16	Seal	10208
17	Cup, Outer	10204
18	Washer	27E14
19	Hub Cap	10207
20	Lug Bolt	10209
21	Cone, Outer	10206
22	Brake Hub	12660

550 DUMP BOX

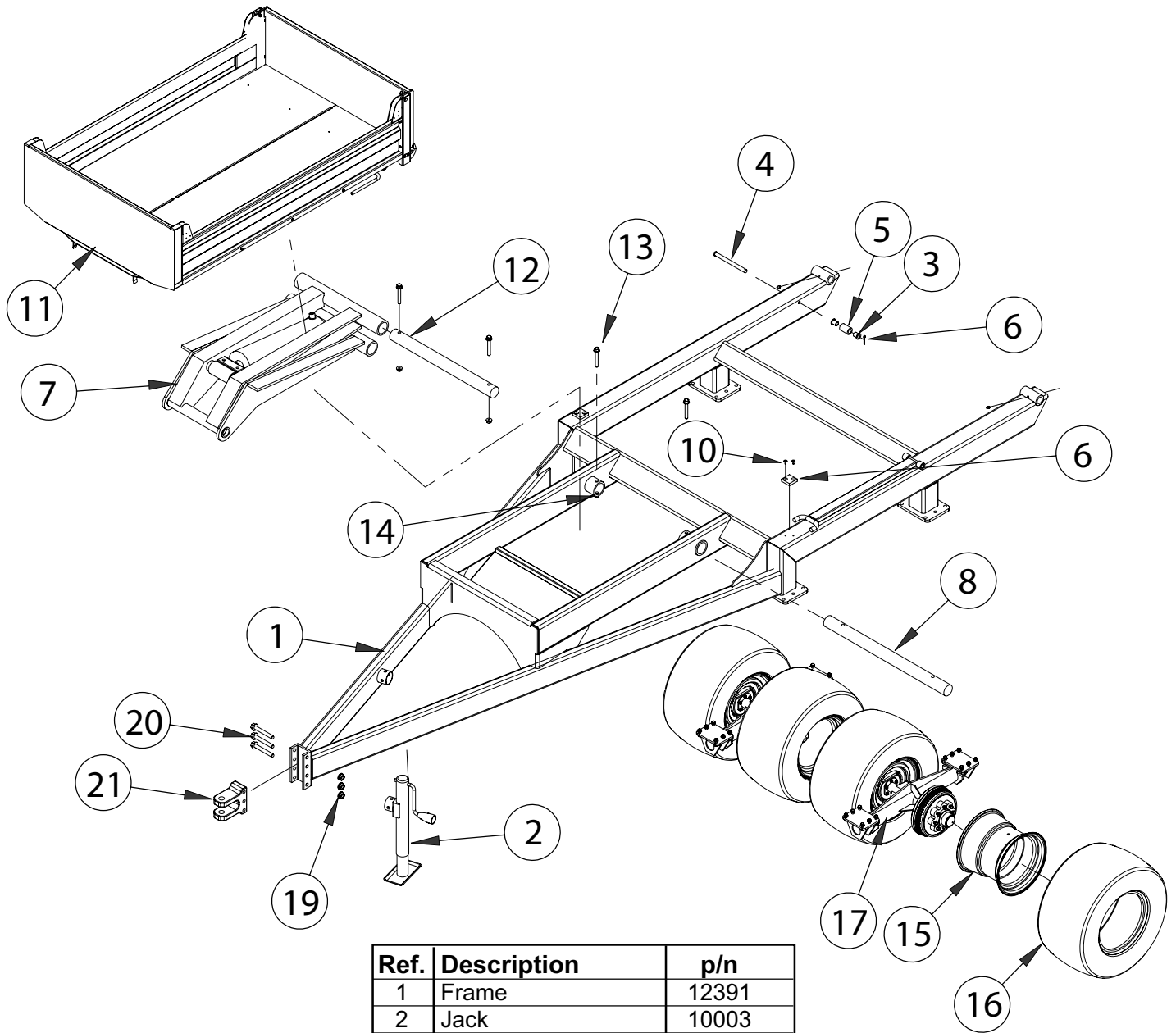

Ref.	Description	p/n
1	Frame	12391
2	Jack	10003
3	Bushing	12457
4	Pin, Pivot	12465
5	Tube	12392
6	Pin, Cotter	1F416
7	Lift Assembly	12450
8	Pin	12453
9	Pad	12456
10	Rivet, Pop	11683
11	Box	12633
12	Pin	12452
13	Screw, Flange Head	35C0856
14	Nut, Flange Head	55D08
15	Wheel	13472
16	Tire, 16 "	11538
17	Axle Assembly	13466
18	Grease Fitting	13548
19	Nut, Flange	89D10
20	Screw, Flange Head	35C1072
21	Hitch, Clevis	12551

550 DUMP BOX

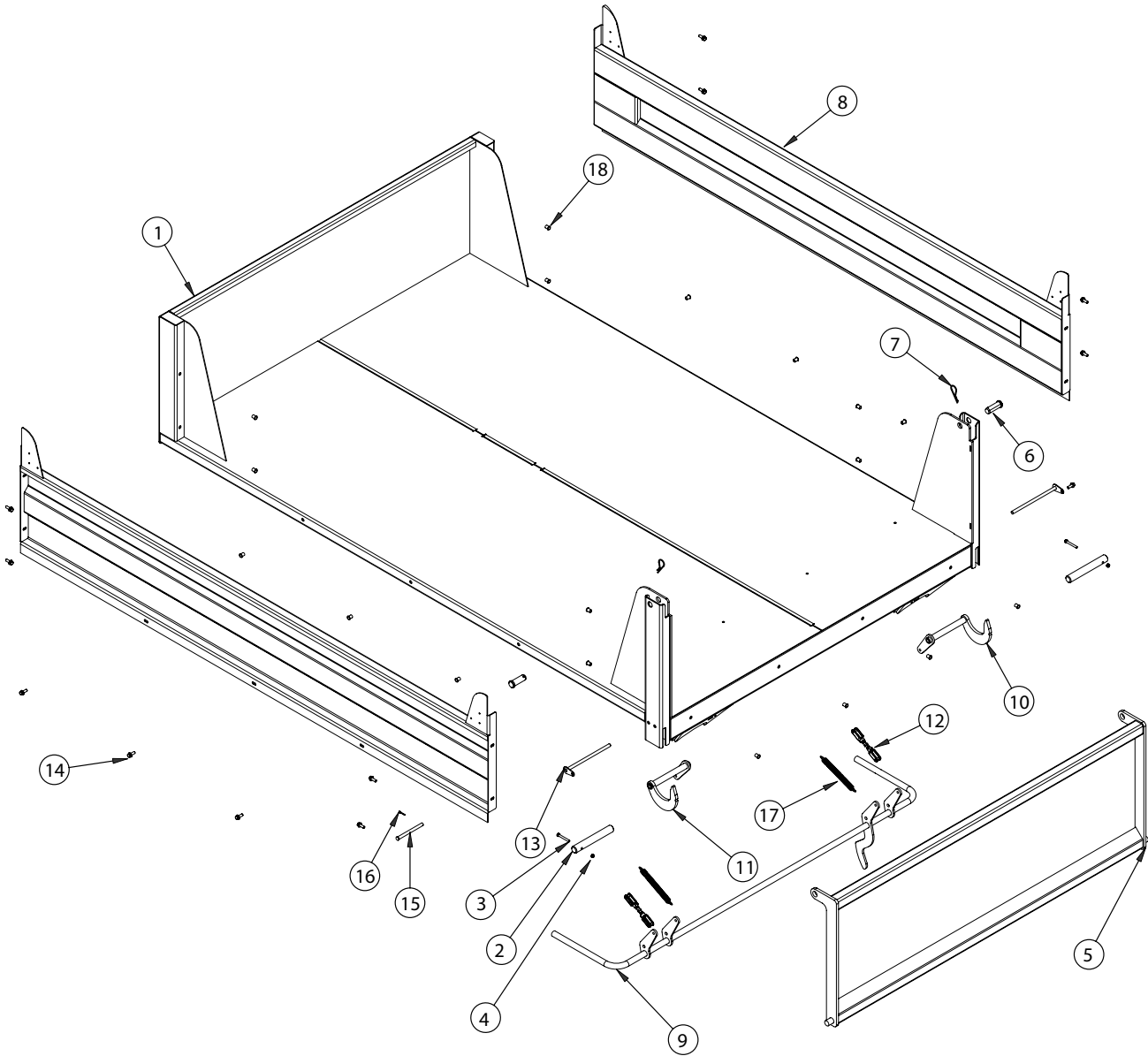

Ref.	Description	p/n
1	Dump Box	12448
2	Pin, Pivot	12451
3	Screw, Cap	1C0540
4	Nut	61D05
5	Tailgate	12444
6	Pin, Clevis	2FR16240
7	Pin, Hitch	12455
8	Box Side	12440
9	Manual Release	12462
10	Right Hook	12394
11	Left Hook	12395
12	Connecting Link	12476
13	Pin, Latch	12459
14	Screw, Flange Head	35C0616
15	Pin, Pivot	12465
16	Pin, Cotter	1F416
17	Spring, Latch	12399
18	Rivnut	11569

550 DUMP BOX

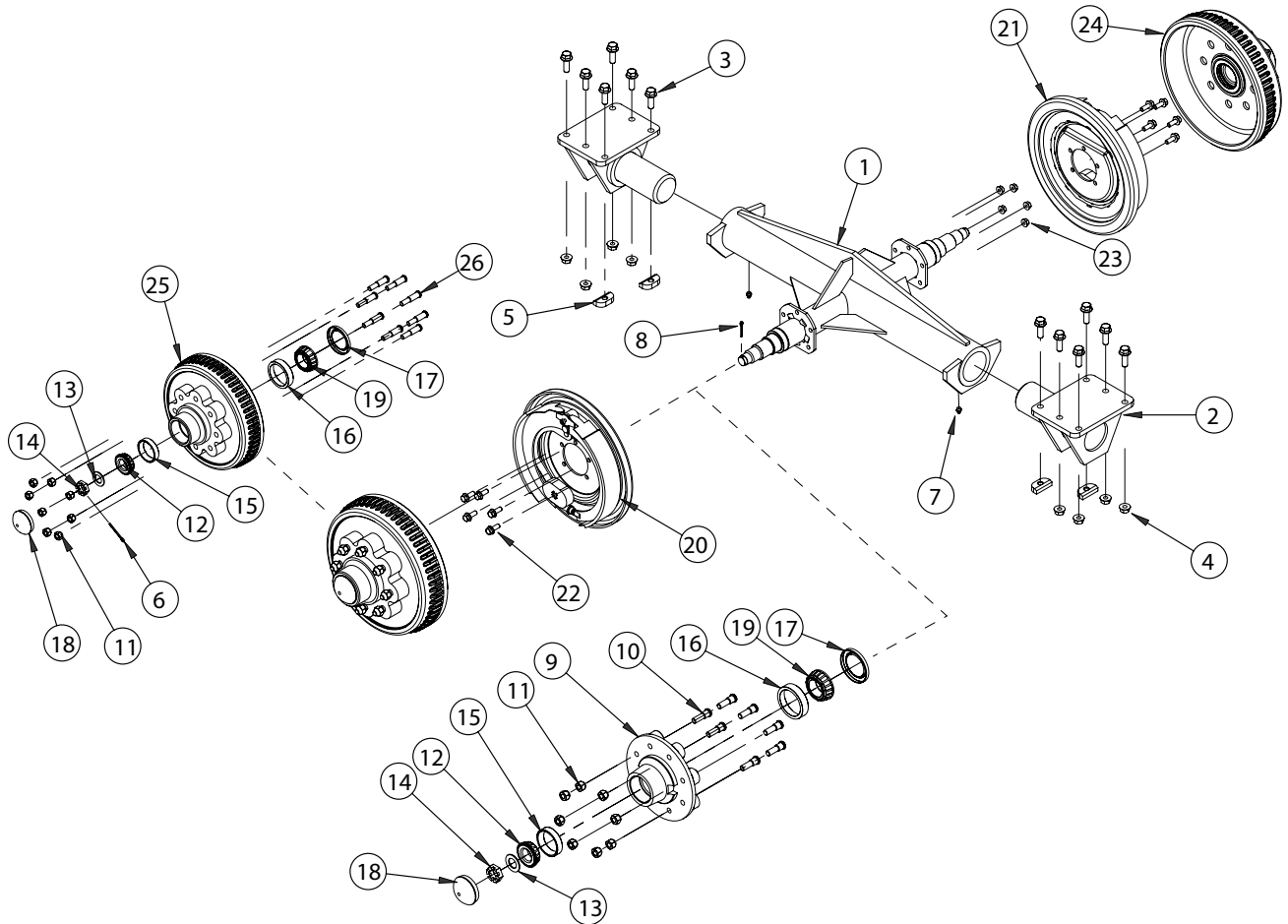

Ref.	Description	p/n
1	Axle	13469
2	Axle Pivot	10685
3	Screw, Flange Head	35C0824
4	Nut, Flange Head	89D08
5	Block, Pivot-Stop	10691
6	Pin, Cotter	1F528
7	Grease Fitting	10H25
8	Pin, Cotter	1F416
9	Hub, Idler	13433
10	Stud, Wheel	12202
11	Nut, Self-Centering	12201
12	Bearing	13425
13	Washer	13431
14	Nut, Castle	13429
15	Cup, Bearing	13426
16	Cup, Bearing	13428
17	Seal, Grease	13432
18	Cap, Grease	13430
19	Bearing	13427
20	Brake Assembly - LH	11149
21	Brake Assembly - RH	11150
22	Screw, Flange Head	35C0616
23	Nut	89D06
24	Brake Hub - RH	13437
25	Brake Hub - LH	13436
26	Stud	13438

WARRANTY

DAKOTA PEAT & EQUIPMENT is hereinafter called DAKOTA™.

(A) Warranty.

DAKOTA™ warrants all products manufactured by it to be free from defects in material and manufactured at the time of shipment and for twelve (12) months from date of delivery to customer. DAKOTA™ will furnish to the dealer, without charge, f.o.b. East Grand Forks, Minnesota, replacements for such parts as DAKOTA™ finds to have been defective at the time of shipment; or at DAKOTA™'s option, will make or authorize repairs to such parts, provided that, upon request, such parts are returned, transportation prepaid, to the factory at East Grand Forks, Minnesota.

This warranty shall not apply to any product that has been subjected to misuse, misapplication, neglect (including but not limited to improper maintenance), accident, improper installation, modification (including but not limited to use of unauthorized parts or attachments), adjustment, or repair. Engines, motors, and any accessories furnished with DAKOTA™'s products, but which are not manufactured by DAKOTA™, are not warranted by DAKOTA™ but are sold only with the express warranty, if any, of the manufacturers thereof. **THE FOREGOING IS IN LIEU OF ALL OTHER WARRANTIES, WHETHER EXPRESS OR IMPLIED (INCLUDING THOSE OF MERCHANTABILITY AND FITNESS OF ANY PRODUCT FOR A PARTICULAR PURPOSE), AND OF ANY OTHER OBLIGATION OF LIABILITY ON THE PART OF DAKOTA.**

(B) Limitation of Liability.

It is expressly understood that DAKOTA™'s liability for its products, whether due to breach of warranty, negligence, strict liability, or otherwise, is limited to the furnishing of such replacement parts, and DAKOTA™ will not be liable for any other injury, loss, damage, or expense, whether direct or consequential, including but not limited to loss of use, income, profit, or production, or increased cost of operation, or spoilage of or damage to material, arising in connection with the sale, installation, use, or inability to use, or the repair or replacement of, DAKOTA™'s products.

Any operation expressly prohibited in the operating instructions or manuals furnished with the machine, or any adjustment, or assembly procedure not recommended or authorized in the operating or service instructions shall void such warranty.

(C) Registration.

THIS WARRANTY IS VOID UNLESS YOUR DEALER COMPLETED AND RETURNED A "NEW PRODUCT REGISTRATION AND WARRANTY" CARD TO DAKOTA™ WITHIN 30 DAYS AFTER DELIVERY OF UNIT TO CUSTOMER.

No Parts shall be returned under warranty unless a Return Goods Authorization (RGA) is obtained from DAKOTA™.

ALWAYS GIVE PART NAME, NUMBER AND MACHINE SERIAL NUMBER WHEN ORDERING PARTS.

NOTE: DAKOTA reserves the right to make changes to design or construction without obligation to incorporate such changes in equipment previously sold.

The tire manufacturer's warranty supplied with your Dakota product may not apply outside the U.S.

YOUR DEALER IS RESPONSIBLE FOR COMPLETION OF THE PRODUCT REGISTRATION CARD AND RETURNING IT TO DAKOTA AS SOON AS YOU TAKE DELIVERY OF YOUR SOILMOVER.

D) Parts, Service, and Warranty

Contact your local dealer for parts, service, and warranty.

**Warranty will be denied if the registration
and warranty card is not sent in within 30
days after delivery.**

NOTES

